



Grasshopper Fender Installation Instructions

For Models: 7020

Thanks for buying these Planet Bike fenders. We designed them to make you want to steer your bike towards big puddles and get through 'em with a smile. If you have any questions regarding installation of the fenders, feel free to check out the FAQs at www.planetbike.com or email us at info@planetbike.com



Hardware Pack / Tools Needed

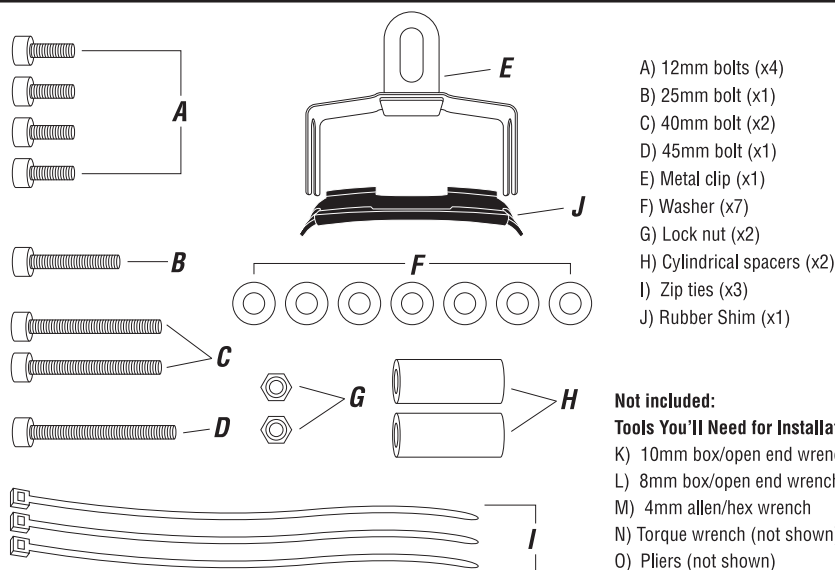

- Not included:**
Tools You'll Need for Installation
 K) 10mm box/open end wrench
 L) 8mm box/open end wrench
 M) 4mm allen/hex wrench
 N) Torque wrench (not shown)
 O) Pliers (not shown)

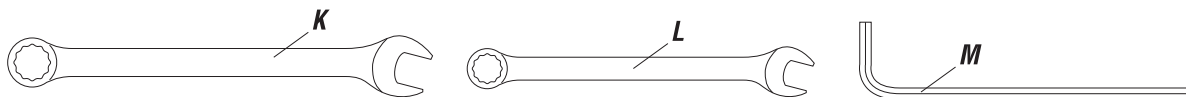

Mounting Instructions

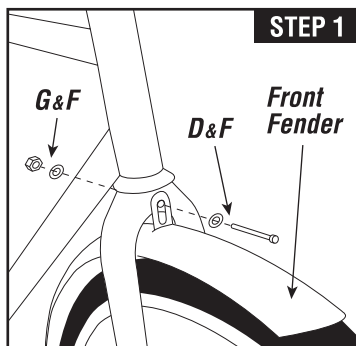

STEP 1: Mounting front fender: Stick the 45mm bolt (D) with washer (F) through the attached tab on the front fender, then through the hole in the fork crown. The tab should mount on the front of the fork crown. Secure with lock nut (G) and washer (F) while keeping the fender centered over the tire. (Tighten to 45 Inlbs or 5.1 Nm.)

Note: Attaching the tab to the back side of the fork is acceptable if it improves fit.

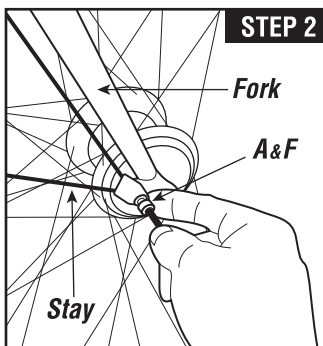

STEP 2: Your fenders come with safety Release Tabs on the front fender that are designed to release the fender stays from the fork if debris becomes lodged in between tire and fender. Using the 12mm bolts (A) and washers (F), bolt the stays (w/ Release Tabs) to the outside of the threaded eyelets on your fork (use lower eyelets if you have two per side). (Tighten to 20 Inlbs or 2.3 Nm.)

Note for disc brakes: If you have disc brakes, thread a 40mm bolt (C) through the stays (w/ Release Tab), then through one of the cylindrical spacers (H), and finally into the eyelet of your fork (disc brake caliper side only). This should get the stays clear of the brakes.

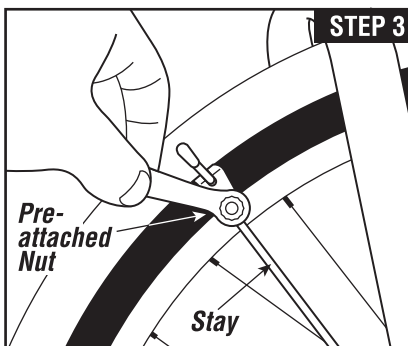

STEP 3: Front fender adjustment: Loosen the 10mm nuts that attach the stays to the front fender and position the fender so that it conforms to the curvature of the tire without rubbing. Make sure you have a minimum of 5 millimeters of clearance between the tire and fender. You may have to adjust the height of the tab mounted to the fork crown (see step 1) to achieve this clearance. Tighten the nuts snugly, but don't use all of your strength or you risk breaking the hardware. (Tighten to 30 Inlbs or 3.4 Nm.)

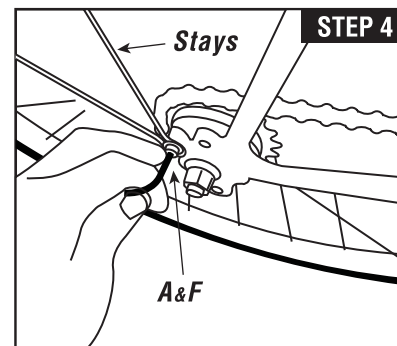

STEP 4: Mounting rear fender: Using two 12mm bolts (A) and two washers (F), bolt the fender stay to the outside of the threaded eyelets on the frame. (Tighten to 35 Inlbs or 4 Nm.)

Note for disc brakes: If you have disc brakes, thread a 40mm bolt (C) through the stay, then through one of the cylindrical spacers (H), and finally into the eyelet of your frame (disc brake side only). This should get the stays clear of the brakes.

Mounting Instructions

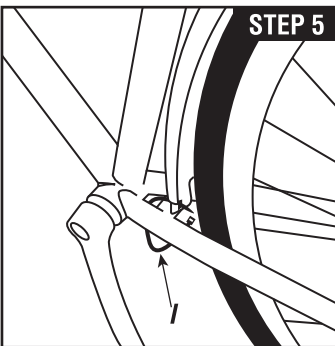

STEP 5

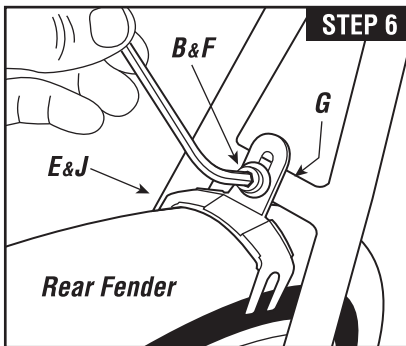

STEP 6

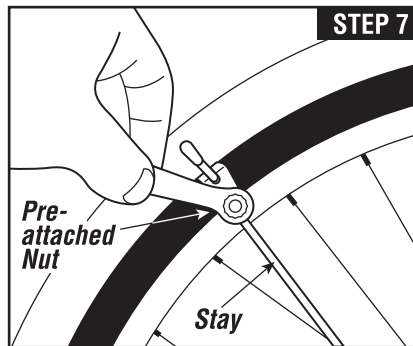

STEP 7

STEP 5: Attach front end of fender to chain-stay bridge using bolt (A) and washer (F) or zip tie (I). If no chain stay bridge is present, fasten fender to the bottom of the seat tube, just above the bottom bracket, with a zip tie.

STEP 6: Install rubber shim (J) onto metal clip (E) making sure the rubber wraps around the edges of the metal clip completely. Bolt the metal clip to the brake bridge using the 25mm bolt (B), washer (F), and lock nut (G). (Tighten to 45 Inlbs or 5.1Nm.) With rear fender centered over the tire, bend the metal clip over the top contour of the fender. Then with a pliers crimp the four tabs (two on each side) around the edges of the fender. Be sure tabs hold fender in place securely. If there is less than 5mm of clearance between the clip and the tire, do not use the fenders.

STEP 7: Rear fender adjustment:

Loosen the 10mm nuts that attach the stays to the rear fender and position the fender so that it conforms to the curvature of the tire without rubbing. Make sure you have a minimum of 5 millimeters of clearance between the tire and fender. Tighten the nuts snugly, but don't use all of your strength or you risk breaking the hardware. (Tighten to 30 Inlbs or 3.4 Nm.) Firmly tighten zip ties on plastic clip near the brake bridge (if used).

STEP 8: Check complete installation to ensure hardware is tight and proper clearance is given between the tire and the fenders. Don't forget to tighten down the zip ties and cut off the extra.

Warranty

We offer a limited lifetime warranty to the original owner of Planet Bike products. Warranty on the finish of the bamboo fenders is one year. Warranty does not cover damage due to accident, abuse, or normal wear and tear. Any modification to Planet Bike products will void all warranty. Proof of purchase is required. Return of the product is required for inspection. Contact your Planet Bike dealer or email us at warranty@planetbike.com

Tips

- Snip off ends of zip ties for clean look
- You can bend the stays to adjust fender position
- Check fender installation before each ride to ensure hardware is tight and in good condition and fender is centered over tire with a minimum of 5mm of clearance.
- To keep the fenders running like new, replace worn parts as needed. Small parts can be found at www.planetbike.com/rebuild
- If you are unsure of any part of the installation process please consult a qualified bicycle mechanic or local bike shop.
- Bamboo is a natural material and will weather with time. The bamboo can be refinished by sanding then sealing with a marine grade varnish.

Warnings

- Check overlap of your toe hitting the front fender while pedaling and turning the front wheel. If there is interference between your toe and front wheel, we do not recommend using fenders.
- There must be a minimum clearance of 5mm between the tire and fender. If you do not have this clearance, fender use is not recommended.
- Planet Bike is not liable for damage or injury as a result of improper installation or improper use.
- If you are unsure of any part of the installation process please consult a qualified bicycle mechanic or local bike shop.

Planet Bike,
2402 Vondron Rd
Madison, WI 53718

