

PROTEGÉ 5.0 INSTRUCTION MANUAL

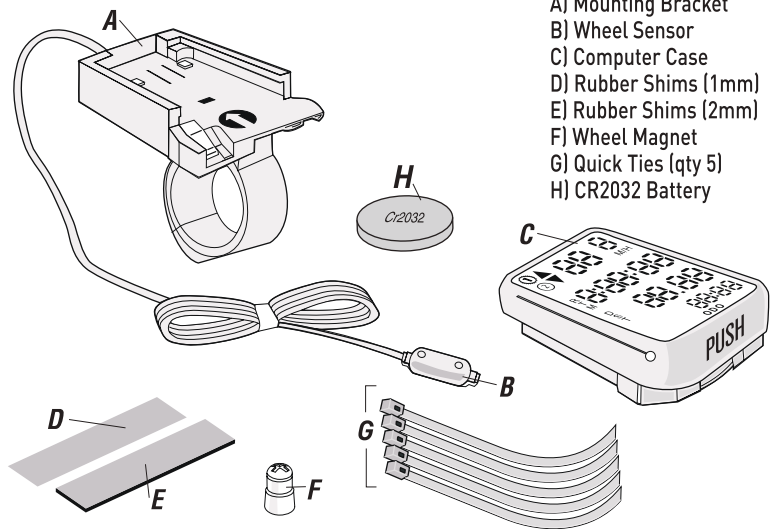

Thank you for purchasing this Planet Bike computer. It's great for training, touring and keeping track of your car-free miles so please take a moment to review this manual so that you can take advantage of all the great features this computer has to offer. Whether you're darting across town or on tour, we hope it accompanies you on many great adventures. Enjoy your new Protégé bicycling computer and have a great ride!

HARDWARE PACK



- A) Mounting Bracket
- B) Wheel Sensor
- C) Computer Case
- D) Rubber Shims (1mm)
- E) Rubber Shims (2mm)
- F) Wheel Magnet
- G) Quick Ties (qty 5)
- H) CR2032 Battery

MOUNTING INSTRUCTIONS

STEP 1: Attach the wheel sensor to the right or left fork using two quick ties (diagram 1). **Note:** Do not fully tighten quick ties until final placement is determined. We recommend a sensor placement of 1-2 inches up from hub axle (diagram 1). Position sensor and wire on backside (toward rider) of fork blade to offer protection from debris while riding.

STEP 2: Attach magnet to spoke using screwdriver (diagram 2) so magnet lines up directly across from one of the flat round dots at the lower or upper portion of wheel sensor with a distance of 2-5 mm between sensor and magnet (diagram 3). **Caution:** Do not over-tighten magnet screw.

STEP 3: Attach the wire harness to the fork using quick ties (diagram 1). Excess wire can be wrapped around brake cable before securing bracket to handlebar. **Note:** Allow slight wire slack between fork and brake cable for turning handlebars.

STEP 4: Attach the computer bracket to the handlebars near the stem (diagram 4). Use any combination of rubber shims to fit different diameter handlebars. Tighten the screw so the bracket will not rotate on the handlebars. Slide the computer head into the bracket until it "snaps" into place.

STEP 5: With the computer head in the bracket, rotate front wheel to test for proper function of magnet/wheel sensor alignment. The mph/kph indicator will flash if the sensor and magnet are properly aligned. Tighten quick ties on sensor when correct alignment is achieved.

TO REMOVE COMPUTER HEAD FROM BRACKET: Push the computer in the opposite direction you would to mount it (diagram 5). The computer head will "snap" out. **Note:** You may have to push hard, or carefully pry with a small screwdriver.

MOUNTING SENSOR

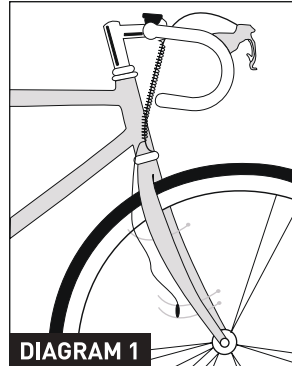

DIAGRAM 1

MOUNTING MAGNET (FRONT WHEEL)

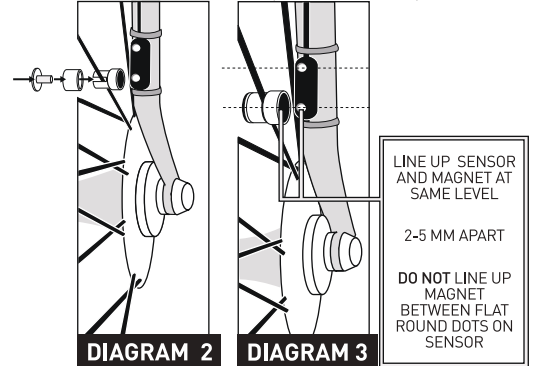

DIAGRAM 2

DIAGRAM 3

LINE UP SENSOR AND MAGNET AT SAME LEVEL
2-5 MM APART
DO NOT LINE UP MAGNET BETWEEN FLAT ROUND DOTS ON SENSOR

MOUNTING BRACKET

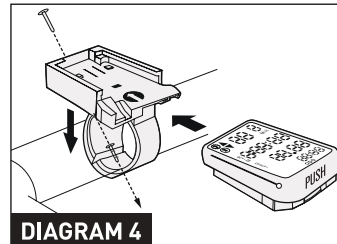

DIAGRAM 4

COMPUTER HEAD REMOVAL

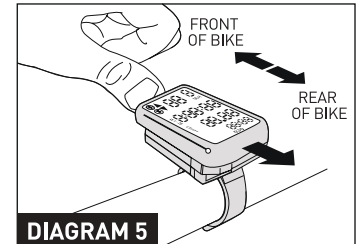

DIAGRAM 5

FUNCTIONS, SPECIFICATIONS + ADDITIONAL FEATURES



LINE: LCD Specification - Line 1, 2, and 3 modes do not change

- 1 **CURRENT SPEED:** Miles or Kilometers per hour - 0 to 99.5 mph/kph - Increments of 0.5 mph/kph
- 2 **RIDE TIME (RTM):** Up to 9:59:59 - Increments of 1 second
- 3 **RIDE DISTANCE (DST):** Up to 999.99 M or K - Increments of 0.01 M or K
- 4 **ODOMETER (ODO):** Up to 99,999.99 M or K - Increments of 0.01 M or K

CHANGE MODE TO SCREEN 2 BY PUSHING COMPUTER FORWARD IN BRACKET TO ACCESS:

OR **CLOCK:** 12 hr format - Indicated by flashing colon ":"

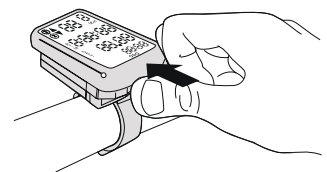

ADDITIONAL FEATURES:

- Auto-Start/Stop - Automatically starts recording data or stops recording data when you start or stop riding
- Auto LCD Off - LCD automatically shuts off to conserve power after 5 minutes of non-use. Clock will still be displayed.
- MacroMonitor™ LCD display displays up to 4 functions at once, allowing for fewer mode changes
- "Buttonless" design for ease of use - push computer forward in bracket to change modes.
- Weather proof construction and heavy duty wire harness for all-weather use.

PUSH AND RELEASE FOR
MODE CHANGE **CAUTION:**
HOLD FOR LESS THAN ONE SECOND OR YOU WILL RESET ALL THE RIDE DATA

COMPUTER SETUP + PROGRAMMING

TO INSTALL THE BATTERY: remove cover by pulling up on the small tab on the battery cover. Install the battery (model CR2032 3V Lithium) with the "+" side facing up. Replace the battery cover, making sure that the rubber gasket is in place and the battery cover is flush. Reinstall the battery cover by lining up indentation and pressing down.

SETUP AND PROGRAMMING are facilitated by using the "set" and "mode" buttons located on the underside of the computer case (diagram 6). To initiate programming, press "mode" button to display SCREEN 1, with "ODO" displayed on line 4. Depress and hold the "set" button for 3-4 seconds (use a pen or small phillips screwdriver). Upon release, the M/H or K/H icon will flash.

STEP 1: MILES OR KILOMETERS SELECTION Once "M/H" or "K/H" is flashing, press "mode" to switch to desired selection. Press "set" to lock in your selection and advance the screen to Wheel Size Setting.

STEP 2: WHEEL SIZE SETTING (WSS) The screen will now display "2154" with the "4" flashing. This is the default "WSS". **Background information:** The bicycle computer calculates information based upon the distance traveled each time your wheel goes around. The wheel size setting equals the distance in mm traveled in one revolution of your wheel. There are two methods to determine the wheel size setting.

METHOD 1: Read the tire size on the side wall of your tire and input the number that corresponds to your tire size on the wheel size chart to the right. Since there are many tire manufacturers and designs, tires listed as the same size from different manufacturers can actually vary significantly in their actual circumference. Therefore, we recommend using Method 2 for maximum accuracy in your computer readings.

METHOD 2: WHEEL ROLL OUT For best results, find a flat smooth surface to perform the wheel roll out and inflate your tires to riding pressure.

A) Place a piece of masking tape or draw a line on the surface to determine a starting position.

B) Position the front tire valve at the 6:00 position (diagram 7) directly above the starting position.

C) Roll the bicycle forward one revolution of the wheel in a straight line until the valve stem is again at the 6:00 position. (Note: Putting pressure on the handle bars to simulate body weight on the tire will give more accurate results.) Mark the finishing position with masking tape or a line. Measure the distance between the starting and finishing positions in mm. This is your WSS. Repeat the procedure if necessary and average the results. (Note: If you use an inch measuring tape, multiply inches by 25.4 to achieve your WSS in mm.)

STEP 3: ENTERING WHEEL SIZE SETTING (WSS)

A) Press "mode" button to change flashing first digit to desired selection.

B) Press "set" button to lock in your selection and advance to the next flashing digit.

C) Repeat steps A-B until all four digits are set. After the fourth digit is set it will advance to the screen Odometer setting.

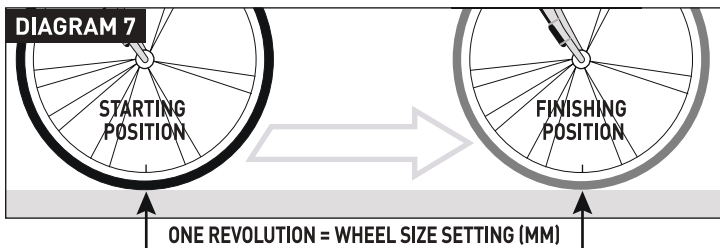

STEP 4: ODOMETER SETTING The digit on the far right will be flashing. (If you don't need to set the Odometer, repeatedly press "set" to advance to clock setting.) Repeat steps A-B again to set the Odometer.

STEP 5: CLOCK SETTING The hour digit on the far left will be flashing. Repeat steps A-B again to set the time. To reset the clock only, press mode button until clock function is displayed on line four. Press "set" button to initiate clock reset. Follow steps A-B above to set the time. When you are done, the computer will enter normal operating mode. Replace the computer in its bracket and you are ready to ride! To reset any other settings, press the mode button until "ODO" appears on line 4. Press and hold the set button for 3-4 seconds. Upon release, the computer will enter "reset" mode. Follow the instructions as above.

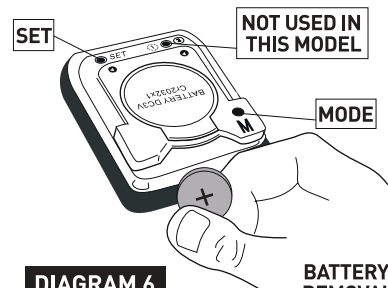

DIAGRAM 6

TIRE SIZE	WSS	TIRE SIZE	WSS
20 x 1.75	1502	700 x 23c	2105
24 x 1.75	1894	700 x 25c	2105
26 x 1 (559mm; 650c)	1925	700 x 28c	2143
26 x 1.25	1950	700 x 32c	2160
26 x 1.5	1996	700 x 35c	2168
26 x 1.95	2055	700 x 38c	2184
26 x 2.1	2070	700 x 40c	2200
26 x 3.0	2170	700 x 45c	2242
26 x 4.0	2288		
27.5 x 1.95	2090		
27.5 x 2.1	2148		
29 x 2.1	2288		
29 x 2.3	2326		

FOR FUTURE REFERENCE, WRITE YOUR WSS HERE:

COMPUTER OPERATION

PRECAUTION: When using the Protégé Bicycle Computer, you should ride safely and pay primary attention to the road, traffic or trail conditions at all times.

MODE CHANGE: Push the computer forward in the bracket as far as it will go and release. The fourth line will change functions. It is recommended that the thumb be positioned in the center of the computer when activating mode changes. Note: do not hold the computer forward in the bracket for more than one second or ride data will be reset to "0".

RESET RIDE DATA: After your ride or before your next ride, you can reset "ride" data (Ride Time, Ride Distance) to "0" by pushing the computer forward in the bracket until ride data clears to "0". Release computer when ride clears to "0".

BATTERY INSTALLATION: The battery should last for 1-2 years with normal use. If you find it necessary to replace the battery, remove the computer from its bracket. (Hint: Record your Odometer mileage before replacing the battery, so you can re-input your Odometer reading after the battery is installed.) Turn the computer over and remove battery cover (diagram 6). Install the battery (Model CR2032 3V Lithium) with the "+" side facing up. Snap battery cover into case until secure. Make sure the rubber water seat gasket is in place and the battery cover is flush with battery case. Refer to Computer Setup and Programming to re-input setup data. Replace the computer in the bracket.

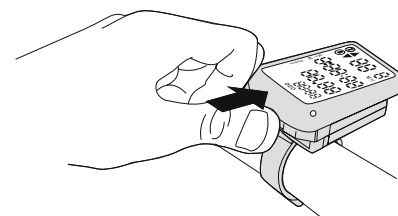

PUSH & HOLD FOR THREE (3) SECONDS TO RESET ALL THE RIDE DATA

TROUBLESHOOTING

1) DISPLAY IS BLANK OR SHOWS PARTIAL DIGITS

Remove and reinsert battery. If problem persists, a new battery may be required.

2) LCD DISPLAYS NUMBERS BUT DOES NOT RECORD DATA WHEN RIDING

Check for proper wheel sensor/magnet alignment (see diagram 3). Check battery in the computer.

3) LCD SCREEN IS DARK

This is normally caused by overheating when the computer is left sitting in the sun. Allow the computer to cool and it should return to normal.

4) THE MODE BUTTON WILL NOT WORK DURING SETUP

This is usually caused by the set button being slightly stuck inside the computer case. Try bending a paper clip and use the end to wiggle the set button around until it pops and is flush with the computer case. This will unlock the mode button and make it possible to set up the computer.

5) THE LCD SCREEN GOES BLANK AND COMPUTER RESETS

Take out the battery and bend the two metal contacts towards to battery to help establish better contact. Re-insert the battery.

If you experience any other problems, contact your Planet Bike dealer or Planet Bike.