

CASCADIA ALX FENDER INSTALLATION INSTRUCTIONS



Thanks for buying these Planet Bike fenders. We design them to make you want to steer your bike towards big puddles and get through them with a smile. Failure to follow installation instructions can result in loss of control, damage, personal injury or death. If you are unsure of any part of the installation process, please consult a qualified bicycle mechanic or local bike shop. If you have any questions regarding installation of the fenders, feel free to check out the FAQs at www.planetbike.com or email us at info@planetbike.com.



For the most up to date installation instructions go to www.planetbike.com/page/support/manuals

HARDWARE PACK / TOOLS NEEDED

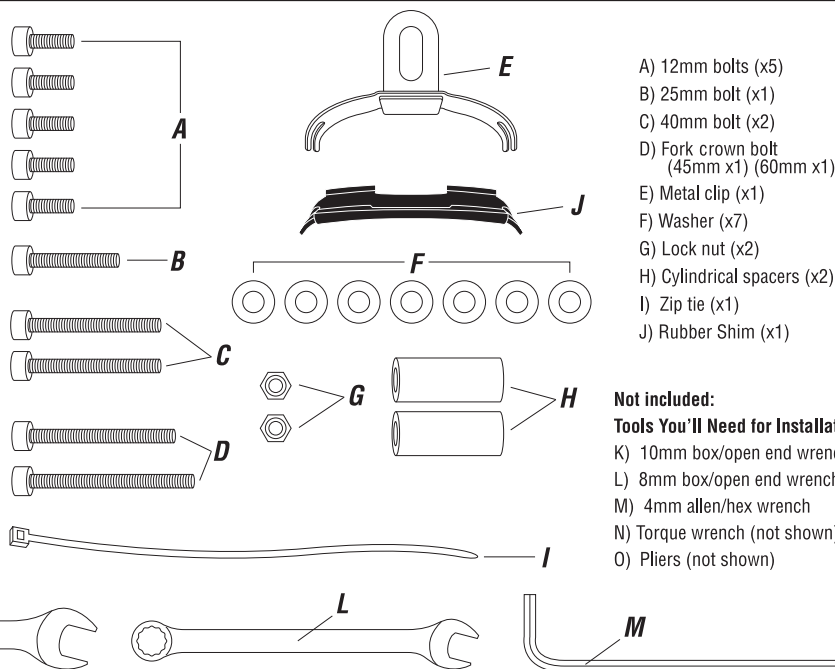

MOUNTING INSTRUCTIONS

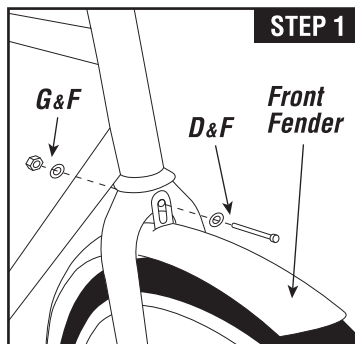

STEP 1: Confirm you have the correct size fenders for your bike. If they do not correspond, do not use fenders. Mounting front fender: Stick the appropriate length fork crown bolt (D) with washer (F) through the attached tab on the front fender, then through the hole in the fork crown. The tab should mount on the front of the fork crown. Secure with lock nut (G) and washer (F) while keeping the fender centered over the tire. Tighten to 45 Inlbs or 5.1 Nm.

Note: Attaching the tab to the back side of the fork is acceptable if it improves fit.

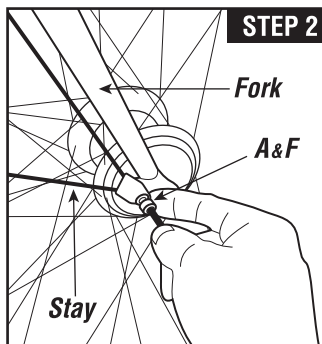

STEP 2: Your fenders come with Release Tabs on the front fender that are designed to release the fender stays from the fork if debris becomes lodged in between tire and fender. Using the 12mm bolts (A) and washers (F), bolt the Release tab/Stay Assembly to the outside of the threaded eyelets on your fork (use lower eyelets if you have two per side). Tighten to 20 Inlbs or 2.3 Nm.

Note for disc brakes: If you have disc brakes, thread a 40mm bolt (C) through the Release tab/Stay Assembly, then through one of the cylindrical spacers (H), and finally into the eyelet of your fork (disc brake caliper side only). This should get the stays clear of the brakes.

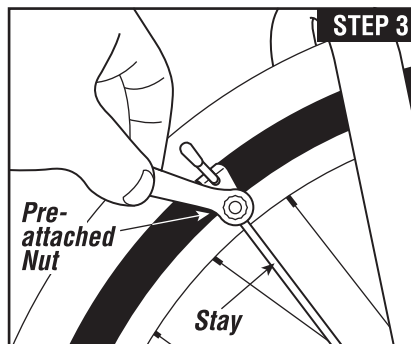

STEP 3: Front fender adjustment: Loosen the 10mm nuts that attach the stays to the front fender and position the fender so that it conforms to the curvature of the tire without rubbing. Make sure you have a minimum of 10 millimeters of clearance between the tire and fender. You may have to adjust the height of the tab mounted to the fork crown (see step 1) to achieve this clearance. Tighten the nuts snugly, but don't use all of your strength or you risk breaking the hardware. Tighten to 30 Inlbs or 3.4 Nm. Check for toe overlap by placing one foot on the pedal positioned at the most forward position. Turn the front wheel. If the tire or fender hits your foot we do not recommend using these fenders.

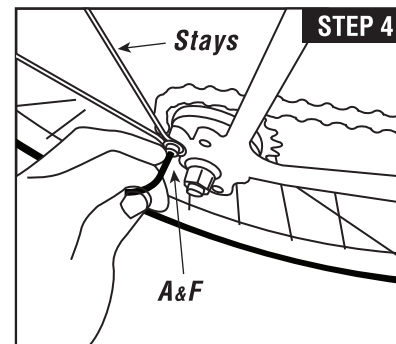

STEP 4: Mounting rear fender: Using two 12mm bolts (A) and two washers (F), bolt the fender stay to the outside of the threaded eyelets on the frame. Tighten to 35 Inlbs or 4 Nm.

Note for disc brakes: If you have disc brakes, thread a 40mm bolt (C) through the stay, then through one of the cylindrical spacers (H), and finally into the eyelet of your frame (disc brake side only). This should get the stays clear of the brakes.

MOUNTING INSTRUCTIONS

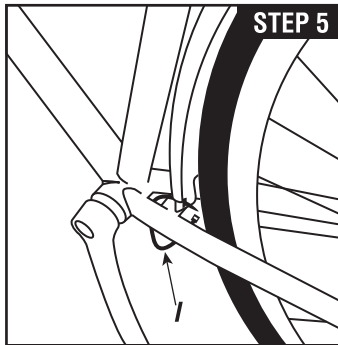

STEP 5: Attach front end of fender to chain-stay bridge using bolt (A) and washer (F) or zip tie (I). If no chain stay bridge is present, fasten fender to the bottom of the seat tube, just above the bottom bracket, with a zip tie.

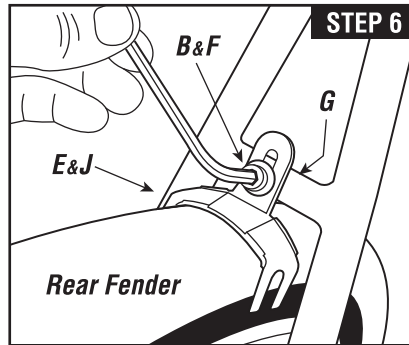

STEP 6: Install rubber shim (J) onto metal clip (E) making sure the rubber wraps around the edges of the metal clip completely. Bolt the metal clip to the brake bridge using the 25mm bolt (B), washer (F), and lock nut (G). Tighten to 45 Inlbs or 5.1Nm. With rear fender centered over the tire, bend the metal clip over the top contour of the fender. Then with a pliers crimp the four tabs (two on each side) around the edges of the fender. Be sure tabs hold fender in place securely. If there is less than 5mm of clearance between the clip and the tire, do not use the fenders.

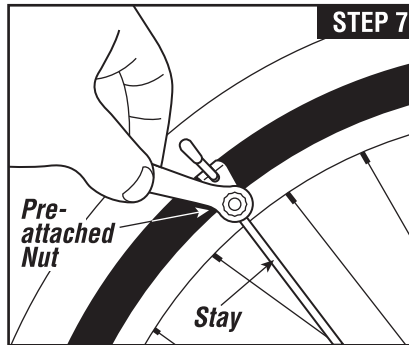

STEP 7: Rear fender adjustment: Loosen the 10mm nuts that attach the stays to the rear fender and position the fender so that it conforms to the curvature of the tire without rubbing. Make sure you have a minimum of 10 mm of clearance between the tire and fender. Tighten the nuts snugly, but don't use all of your strength or you risk breaking the hardware. Tighten to 30 Inlbs or 3.4 Nm.

STEP 8: Check complete installation to ensure hardware is tight and proper clearance is given between the tire and the fenders. Don't forget to tighten down the zip ties and cut off the extra.

GOOD GEAR GUARANTEE

We make quality products and they include a limited lifetime warranty to the original owner of our products. These fenders are warranted to be free from defects in materials and workmanship for as long as the original purchaser owns the product. This warranty does not cover damage due to accident, abuse, or normal wear and tear. This warranty is void if the fenders or fender mounting hardware are modified, or are not properly installed on a bicycle for which they



were designed. To make a claim under this warranty, return the fenders together with proof of purchase, to the retail dealer from which they were purchased, or contact Planet Bike directly. Purchaser's sole remedy pursuant to this warranty is for Planet Bike to repair or replace the faulty part(s). Planet Bike provides no other warranty, expressed or implied. This warranty gives you specific legal rights; you may also have other rights which vary from state to state.

WARNINGS

- Check overlap (touching your foot on the fender or wheel while turning) as described in step 3. If there is interference between your toe and front wheel, we do not recommend using these fenders.
- Check for interference with other bike components, especially brakes and drive train. If interference is present readjust fenders. If interference remains, do not use the fenders.
- There must be a minimum clearance of 10mm between the tire and fender. If you do not have this clearance, fender use is not recommended.
- It may be necessary to install a smaller (narrower) tire on your bicycle to create space for fenders between the tires and the bicycle frame.
- Failure to follow installation instructions can result in loss of control, damage, personal injury or death.

- Check fender installation before each ride to ensure hardware is tight and in good condition and fender is centered over tire with a minimum of 10mm of clearance.
 - If release tab is released, inspect for damage. Replace damaged release tabs immediately and reassemble tabs.
 - These fenders are not intended for off road riding, competitive use, or excessive speeds.
 - To keep the fenders functioning safely, replace worn parts as needed. Small parts can be found at www.planetbike.com/rebuild
 - **If you are unsure of any part of the installation process please consult a certified bicycle mechanic or local bike shop.**
- *For the most up to date installation instructions, go to www.planetbike.com/page/support/manuals

TIRE REFERENCE GUIDE

PB#	DESCRIPTION	MAX TIRE
7056-8	Cascadia ALX 700 Medium, Black	700x35
7056-6	Cascadia ALX 700 Medium, Silver	700x35
7058-8	Cascadia ALX 700 Narrow, Black	700x25
7055-8	Cascadia ALX 700 Wide, Black	700x40
7050-8	Cascadia ALX 20" Medium, Black	20x1.5
7051-8	Cascadia ALX 20" Wide, Black	20x1.9
7052-8	Cascadia ALX 26" Narrow, Black	26x1.5
7057-8	Cascadia ALX 26" Wide, Black	26x1.9
7057-6	Cascadia ALX 26" Wide, Silver	26x1.9
7053-8	Cascadia ALX 27.5 Medium, Black	27.5x1.5
7054-8	Cascadia ALX 27.5 Wide, Black	27.5x1.9
7059-6/8	Cascadia ALX 29" Medium, Black	29x2