

CASCADIA FENDER INSTALLATION INSTRUCTIONS



FOR MODELS: 7056, 7056-5, 7057, 7057-5, 7058, 7058-5, 7059

Thanks for buying these Planet Bike fenders. We design them to make you want to steer your bike towards big puddles and get through them with a smile. Failure to follow installation instructions can result in loss of control, damage, personal injury or death. If you are unsure of any part of the installation process, please consult a qualified bicycle mechanic. If you have any questions regarding installation of the fenders, feel free to check out the FAQs at www.planetbike.com or email us at info@planetbike.com.



For the most up to date installation instructions go to www.planetbike.com

HARDWARE PACK / TOOLS NEEDED

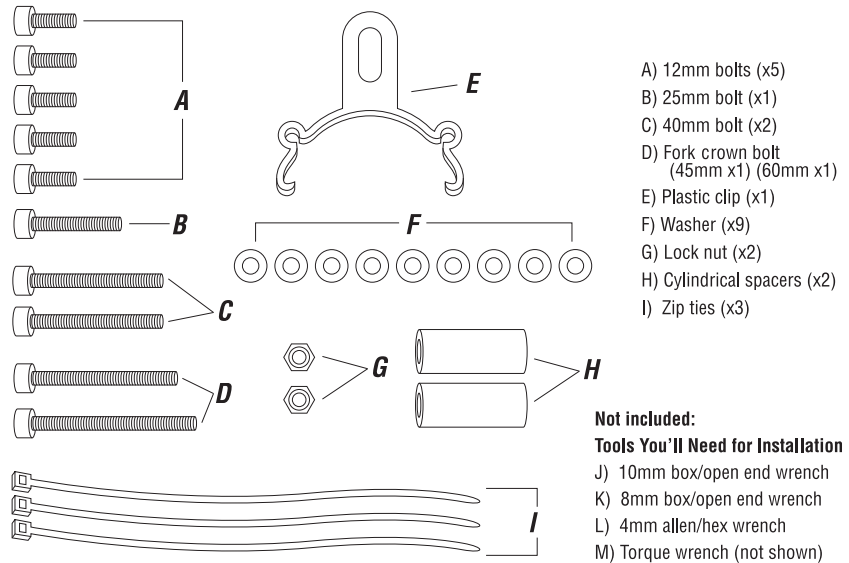

Not included:

Tools You'll Need for Installation

- J) 10mm box/open end wrench
- K) 8mm box/open end wrench
- L) 4mm allen/hex wrench
- M) Torque wrench (not shown)

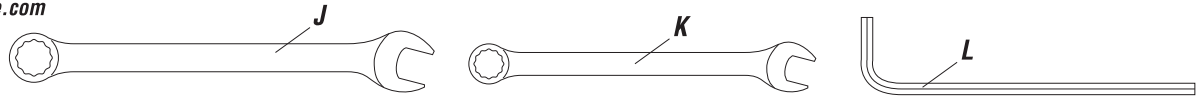

MOUNTING INSTRUCTIONS

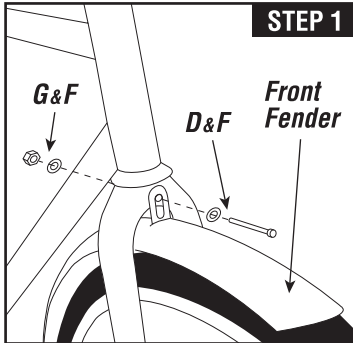

Step 1: Consult the below Tire Reference Guide to confirm you have the correct size fenders for your bike. If your tires are larger than our recommended maximum tire width, do not install fenders. **Mounting front fender:** Stick the appropriate length fork crown bolt (D) with washer (F) through the attached tab on the front fender, then through the hole in the fork crown. Tab can mount in front or behind fork for best fit. Secure with lock nut (G) and washer (F) while keeping the fender centered over the tire. You will need to use both an 8mm box wrench (K) and 4mm hex wrench (L). Tighten to 45Inlbs or 5.1 Nm.

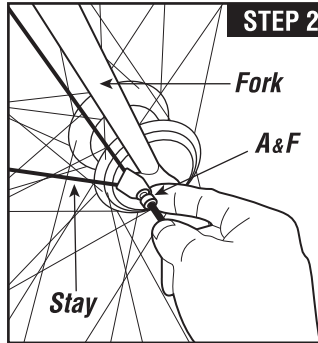

Step 2: Your fenders come with Release Tabs on the front fender that are designed to release the fender stays from the fork if debris becomes lodged in between tire and fender. Using the 12mm bolts (A) and washers (F), bolt the release Tab/Stay Assembly to the outside of the threaded eyelets on your fork (use lower eyelets if you have two per side). (Tighten to 20 Inlbs or 2.3 Nm.) **Note for disc brakes:** If you have disc brakes, thread a 40mm bolt (C) through the Release Tab/Stay Assembly, then through one of the cylindrical spacers (H), and finally into the eyelet of your fork (disc brake caliper side only). This should get the stays clear of the brakes.

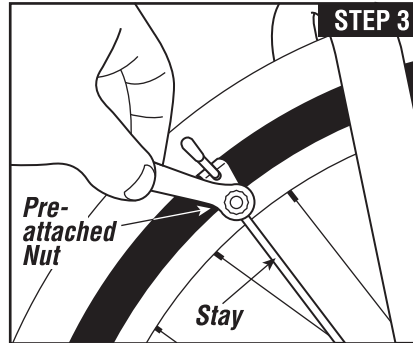

Step 3: Front fender adjustment: Loosen the 10mm nuts that attach the stays to the front fender and position the fender so that it conforms to the curvature of the tire without rubbing. Make sure you have a minimum of 10mm of clearance between the tire and fender. You may have to adjust the height of the tab mounted to the fork crown (see step 1) to achieve this clearance. Tighten the nuts snugly, but don't use all of your strength or you risk breaking the hardware. (Tighten to 30 Inlbs or 3.4 Nm.) Check for toe overlap by placing one foot on the pedal positioned at the most forward position. Turn the front wheel. If the tire or fender hits your foot we do not recommend using these fenders.

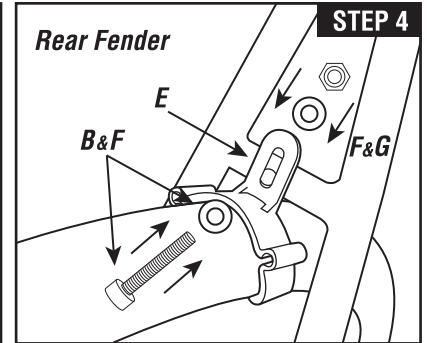

Step 4: Mounting Rear fender: Remove rear wheel. Snap the plastic clip (E) onto the rear fender and bolt it to the seat stay bridge using the 25mm bolt (B) and washer (F). Secure with lock nut (G) and washer (F). Tighten to 45 in lbs or 5.1 Nm



MOUNTING INSTRUCTIONS

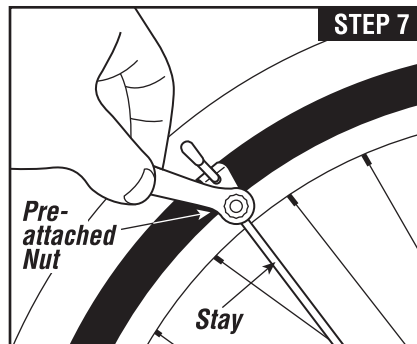
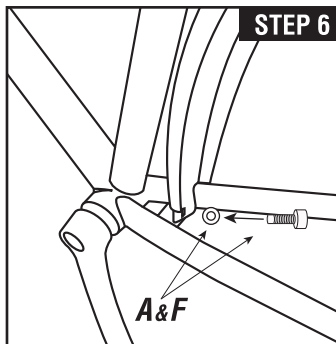
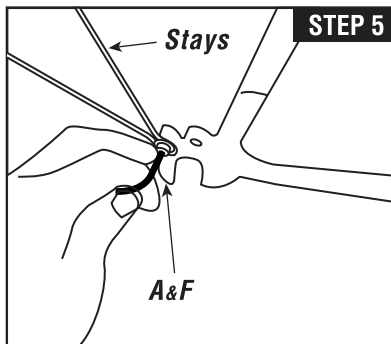
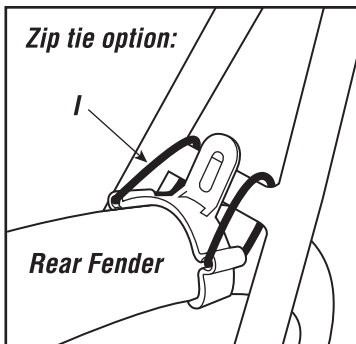

Zip tie option: If the bridge has no hole, thread 2 zip ties (I) through the channels in the plastic clip. Before you firmly tighten the zip ties, proceed through steps 5, 6 and 7. If no seat stay bridge is present, we do not recommend using these fenders.

Step 5: Using two 12mm bolts (A) and two washers (F), bolt the fender stays to the outside of the threaded eyelets on the frame. (Tighten to 35 lnlbs or 4 Nm.)

Note for disc brakes: If you have disc brakes, thread a 40mm bolt (C) through the stay, then through one of the cylindrical spacers (H), and finally into the eyelet of your frame (disc brake side only). This should get the stays clear of the brakes.

Step 6: Attach front end of fender to chain-stay bridge hole using bolt (A) and washer (F). If no chain stay bridge hole is present, fasten fender to the bridge with a zip tie(I). If no chain stay bridge is present, we do not recommend using these fenders.

Step 7: Rear fender adjustment: Attach rear wheel to bike. Loosen the 10mm nuts that attach the stays to the rear fender and position the fender so that it conforms to the curvature of the tire without rubbing. Make sure you have a minimum of 10mm of clearance between the tire and fender. Tighten the nuts snugly, but don't use all of your strength or you risk breaking the hardware. (Tighten to 30 lnlbs or 3.4 Nm.) Firmly tighten zip ties on plastic clip near the seat stay bridge (if used).

Step 8: Check complete installation to ensure hardware is tight and proper clearance is given between the tires and the fenders. Don't forget to tighten down the zip ties and cut off the extra.

GOOD GEAR GUARANTEE

We make quality products and they include a limited lifetime warranty to the original owner of our products. These fenders are warranted to be free from defects in materials and workmanship for as long as the original purchaser owns the product. This warranty does not cover damage due to accident, abuse, or normal wear and tear. This warranty is void if the fenders or fender mounting hardware are modified, or are not properly installed on a bicycle for which they were designed. To make a claim under this warranty, return the



fenders together with proof of purchase to the retail dealer from which they were purchased or contact Planet Bike directly. Purchaser's sole remedy pursuant to this warranty is for Planet Bike to repair or replace the faulty part(s). Planet Bike provides no other warranty, expressed or implied. This warranty gives you specific legal rights; you may also have other rights which vary from state to state.

WARNINGS

- Check for toe overlap as described in step 3. If there is interference between your toe and front wheel, we do not recommend using these fenders.
- Check for interference with other bike components, especially brakes and drive train. If interference is present readjust fenders. If interference remains, do not use the fenders.
- There must be a minimum clearance of 10mm between the tire and fender. If you do not have this clearance, fender use is not recommended.
- It may be necessary to install narrower tires on your bicycle to create appropriate space between the tires and fenders.
- Any modification to the fender installation instructions is not recommended. Failure to follow installation instructions can result in loss of control, damage, personal injury or death.

- Check fender installation before each ride to ensure hardware is tight and in good condition and fender is centered over tire with a minimum of 10mm of clearance.
 - If release tab is released, inspect for damage. Replace damaged release tabs immediately and reassemble tabs.
 - These fenders are not intended for off road riding, competitive use, or excessive speeds.
 - We do not recommend transporting bike with mounted fenders on an automobile or bus bike rack. Forces exerted on fenders at high speeds have the potential of damaging the fenders.
 - To keep the fenders functioning safely, replace worn parts as needed. Small parts can be found at www.planetbike.com
 - **If you are unsure of any part of the installation process please consult a certified bicycle mechanic.**
- *For the most up to date installation instructions, go to www.planetbike.com

TIRE REFERENCE GUIDE

PB#	DESCRIPTION	MAX TIRE
7056-5	Cascadia 700 x 45mm, black	700 x 35
7056	Cascadia 700 x 45mm, silver	700 x 35
7058-5	Cascadia 700 x 35mm, black	700 x 25
7058	Cascadia 700 x 35mm, silver	700 x 25
7057-5	Cascadia 26" x 60mm, black	26 x 1.9
7057	Cascadia 26" x 60mm, silver	26 x 1.9
7059	Cascadia 29" x 65mm, black	29 x 2